

h

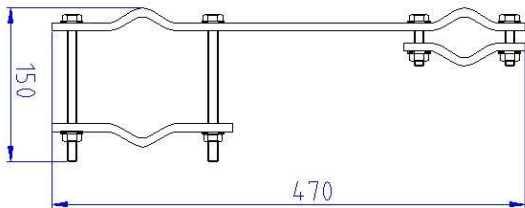
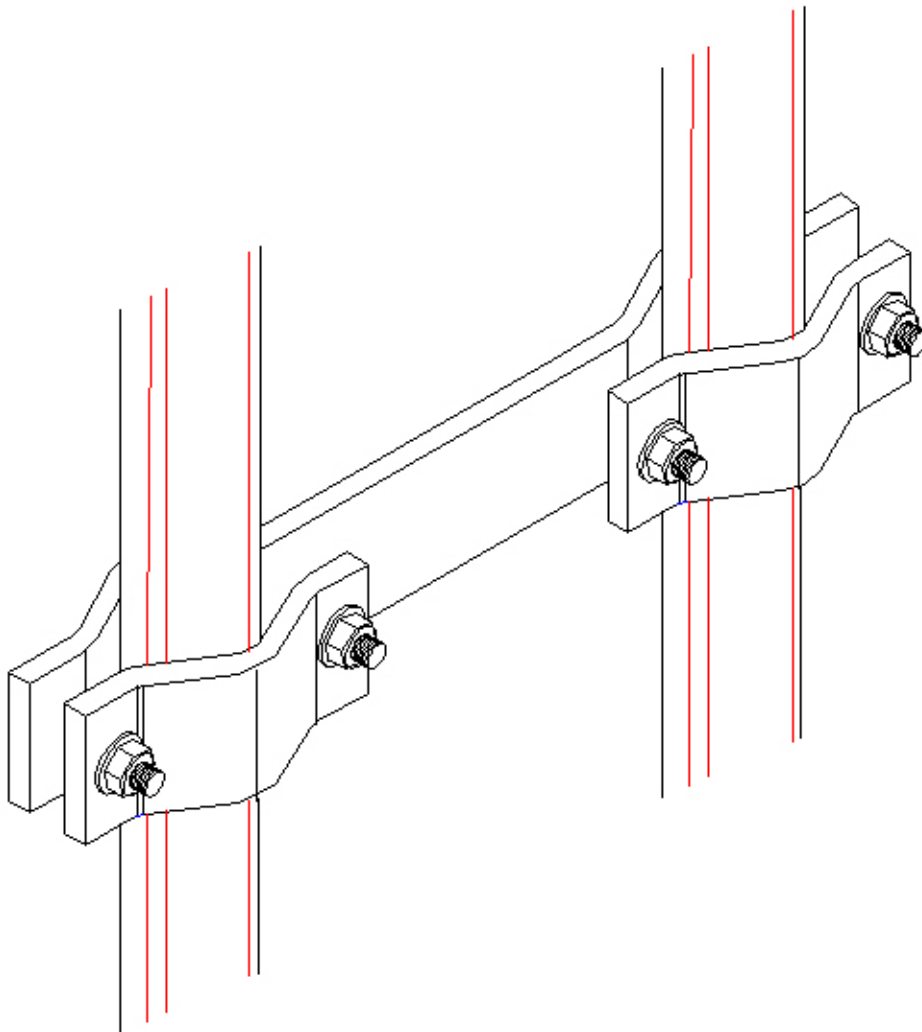

- *Used for lightning conductors fixing directly on towers, vertical pipes, metal framework*
- *Equipped with:*
 - 4 inox screws A2 DIN 933TH M10*140
 - 4 inox screws A2 DIN 933TH M10*60
 - 4 inox screws A2 DIN 934 HU10
 - 8 inox flat washer A2 M10
- *Material : Galvanized steel*
- *Dimensions : 150 x 40 x 470 mm*
- *Weight : 2,27 kg*

Franklin France
B.P. 106
13 Rue Louis Armand
77834 Ozoir-La-Ferrière

Product denomination : **Lateral fixing**
Product reference : **AFZ 0513 SL**

CS-209